

CRYOGENIC™ PORTABLE DEFLASHING SYSTEM

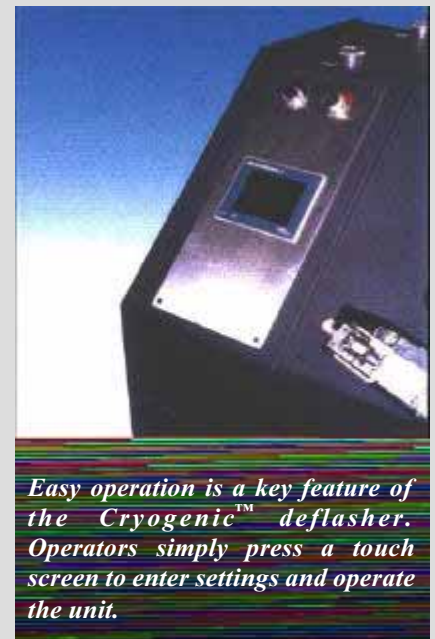

PORTABLE CRYOGENIC DEFLASHER MOVES WHERE YOU NEED IT, SAVES VALUABLE WORKSPACE

Affordable and portable, the Cryogenic™ deflasher takes cryogenic deflashing to a new level...

It lets you move your finishing process to any area of the plant and provides production capability of up to 1.28 cu. ft. of parts per load.

No special power or liquid nitrogen installation is required. Simply plug the deflasher into any 115V outlet and connect to a liquid nitrogen supply-either portable vessels or bulk tank.

Compact and easy to operate, the Cryogenic deflasher offers many features found only in large stationary units.

- A 10,000 rpm throw wheel provides high production throughput.
- Adjustable variable speed controls allow fine adjustment of the throw wheel, tumble basket and media auger.
- Automatic temperature control and safety limit switches assure trouble-free operation.

Constructed of stainless steel and aluminum, the system combines the best of reliable operation with compact portability.

**Hull
Industries Inc**

7 Britain Drive
New Britain, PA 18901
Phone: 215.230.4260
Fax: 215.230.4261
www.hullindustries.com

CRYOGENIC™ PORTABLE DEFLASHING SYSTEM

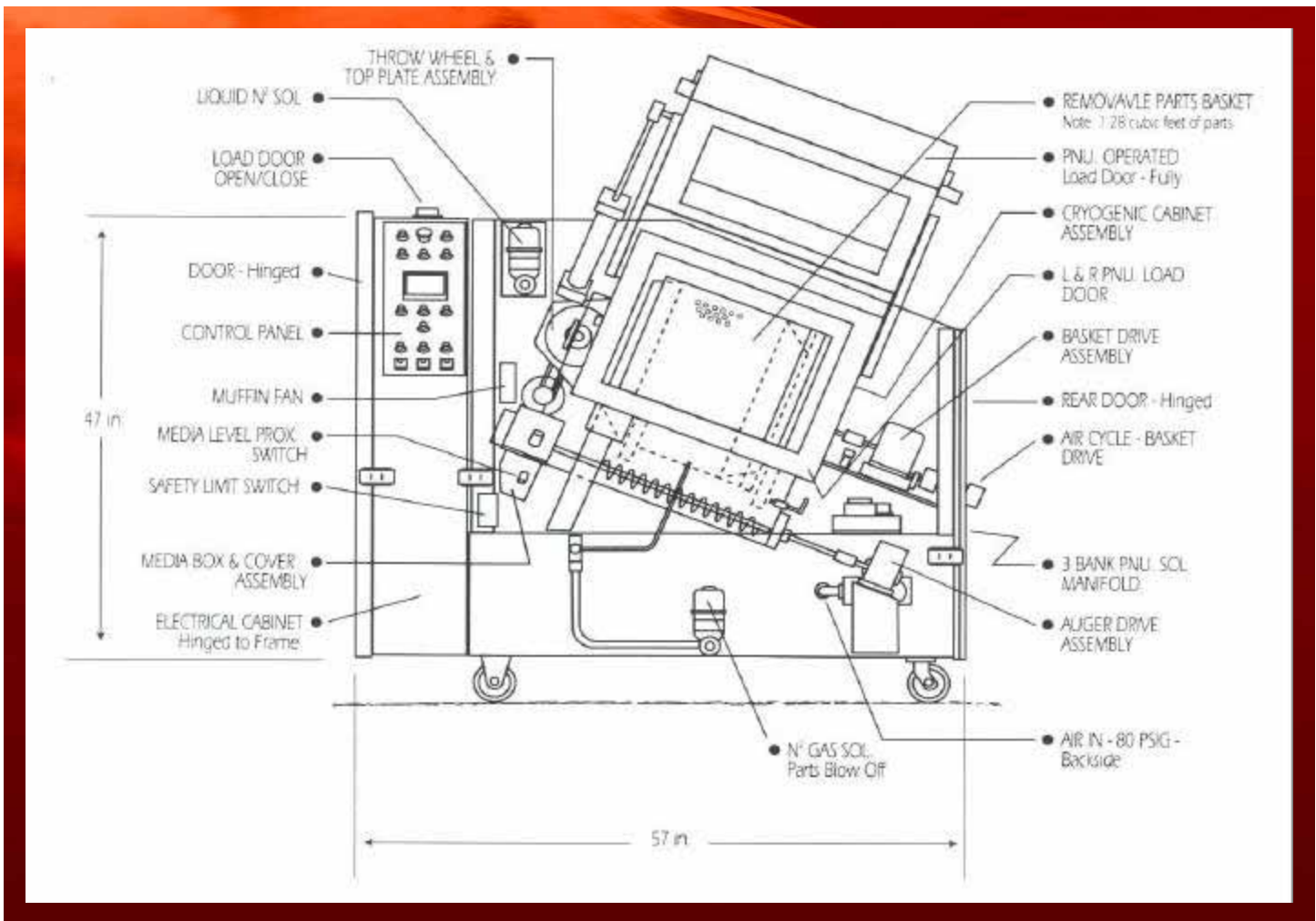

SPECIFICATIONS

- Power: 115V, 60Hz, 15 amp
- Emergency stop and ON/Off switch
- Automatic/Manual mode control
- Automatic temperature controller (+32 to -250F)
- Throw wheel rpm digital readout
- Throw wheel variable speed control, 0-10,000 rpm
- Tumble basket speed control
- Media auger speed control
- Cycle timer
- Optional media separator
- Durable powder coat and stainless steel finish
- Gas shock load door assist
- Load capacity: 1.28 cu. ft. of parts
- Construction: stainless steel and aluminum

**Hull
Industries Inc**

7 Britain Drive
New Britain, PA 18901
Phone: 215.230.4260
Fax: 215.230.4261
www.hullindustries.com